

Meccano Electrics.

Andrew Knox, Meccano Society of Scotland. (ISM 1061)

In this short series of articles a number of different electrical and electronic components will be discussed with a view to explaining how they may easily be included in Meccano models. Wherever possible, maths will be avoided. Some arithmetic is required, however. All of the parts discussed are available from local electronics suppliers such as RS Components (who now sell to anyone), Farnell, Rapid Electronics, Maplin, and many others.

Coverage of the following major topics is planned:

1. Introduction and basic terminology.
2. Transformers.
3. Switches and Diodes (Part A): Basic control circuits.
4. Light-emitting diodes.
5. Motors and Batteries.
6. Switches and Diodes (Part B): Hysteresis and rectification.
7. Variable voltage supplies and heatsinks.
8. Microprocessor control and the “H” bridge.
9. Infrared and radio remote control.

1. Basic terminology.

Electricity comes in two different formats – Direct Current or simply D.C. – what batteries produce, and Alternating Current or simply A.C. – what is supplied to households. When a voltage is applied to a resistance (e.g. a car battery connected to a headlight bulb or household mains connected to the heating element of a toaster), a current flows. Voltage is measured in volts and current is measured in amps. Ohm’s law says Voltage = Current x Resistance or the short-hand form: $V = I \times R$.

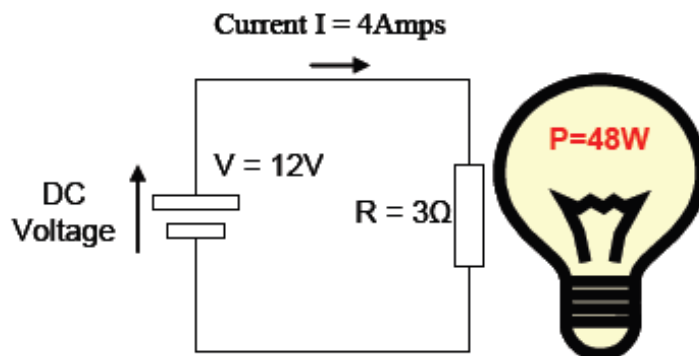

Figure 1 – Current, Voltage and Power.

Power, the amount of work done, is measured in Watts after Watt of steam engine fame. In electrical terms, power is found by multiplying the voltage by the current, regardless of

whether it is AC* or DC. Suppose a car headlight bulb has a resistance of 3 ohms and the car electrical system is 12V DC, then the current that will flow in the bulb is given by $I = V / R$ which equals $12V / 3\Omega$ or 4 amps. Power is $V \times I = 12V \times 4A = 48W$. This is shown in Figure 1, above. (The actual power of a car headlight bulb is about 55W, giving a hot resistance of approximately 2.6Ω .)

For the toaster, if the voltage to the house is 250V AC and the toaster's power is 1,000 Watts (a kilowatt or kW) then the current flowing is given by $P / V = 1,000 / 250 = 4A$. A 13 amp plug can therefore supply about 3.2kW before becoming overloaded (which is what most older washing machines consume, hence why the washing machine's plug is often warm to the touch.) Finally, a unit of electricity as measured by the meter in the house is a kilowatt-hour – in other words a power of one kilowatt used for one hour. If an electric kettle has a power rating to 2kW then it uses one unit of electricity every 30 minutes and a 100W light bulb can be run for 10 hours before a whole unit of electricity is consumed. A unit is actually quite a lot, hence why the meter has a couple of digits after the decimal point.

In mechanical terms, horsepower is a measure of work done and equals 746W electrical†. Horsepower was originally invented to allow the comparison of steam engines and draft horses, and (rather optimistically for the horse) was defined as the power required to raise a weight of 550 lbs a distance of one foot in one second. A 1 horsepower steam engine appeared to do more work than a draft horse and hence the salesman had an easy job convincing the unsuspecting customer to purchase an engine.

2. The transformer.

The transformer is used to change the voltage and current of an AC supply. It is made by winding two‡ coils of wire on a metal core and acts in an analogous way to a mechanical gearbox. Like the gearbox, it has an input (the “primary” winding) and an output (the “secondary” winding), but instead of transforming RPM and torque, voltage and current are transformed. A “step-down” transformer converts the input voltage to a lower output voltage (e.g. 250V AC to 12V AC for model trains) and a “step-up” transformer does the opposite (e.g. as used in old televisions and valve radios to give the high voltage supply to the anodes of the valves). Like the gearbox, a transformer has a certain efficiency: the output power is always less than the input power, with the difference being lost as heat, sound, vibrational energy, and so on. In transformer-speak, the amount of power that can be safely delivered is expressed as “volt-amperes” or VA – simply the product of the voltage (in units of volts) and the current (in units of amps) on the secondary winding.

Extending the analogy, voltage is equivalent to RPM and current is equivalent to torque. If we assume for a moment the efficiency is 100%, then as the voltage (RPM) is reduced, the current (torque) is increased, just like in a reduction gearbox. For the example of the model train transformer, the reduction ratio is 250:12 or a little over 20:1. Where the

* Strictly speaking, power in AC circuits depends on the phase angle between the voltage and current waveforms. That particular complication will be overlooked in these articles.

† Not to be confused with the metric horsepower used in Europe of approx 735W.

‡ An autotransformer uses a single coil but does not provide electrical isolation.

analogy breaks down is when considering the stationary condition – the gearbox can provide a holding torque whereas the transformer *must* have an AC voltage to work with. If you apply DC to a transformer all that will happen is that it will get hot and eventually blow the fuse. Permanent internal damage to the transformer caused by overheating will almost certainly occur as well.

Transformers are fairly robust bits of equipment and will take quite a bit of abuse for short periods. However, they have a voltage and current rating that must be respected. If you connect a transformer the wrong way around and try to step up the mains voltage the electrical insulation on the windings will fail and cause permanent damage (usually accompanied by a loud bang and a bad smell). The current rating is also important – if the transformer gets too hot, once again the insulation will fail.

The usual warnings apply about using mains voltage on Meccano models, and wiring up transformers. Unless you're absolutely sure you know what you're doing, best to err on the side of safety and purchase a pre-wired transformer. In the event there is no alternative to using the mains voltage on a model it is prudent to connect a protection device to the system before any exposed metalwork. These are variously called "power breakers" (as used on the electric hedge trimmer for example), "earth leakage circuit breakers", (ELCBs) or "residual current circuit breakers" (RCCBs). All work in a similar way and detect an imbalance in the current flowing in the live and neutral conductors (because, for example, some current is passing through you to earth rather than flowing in the neutral wire) and switch off the power. Note these devices cannot tell the difference between transformers and humans, and if you're unfortunate enough to come in contact with both live and neutral simultaneously they will not afford any protection whatsoever.

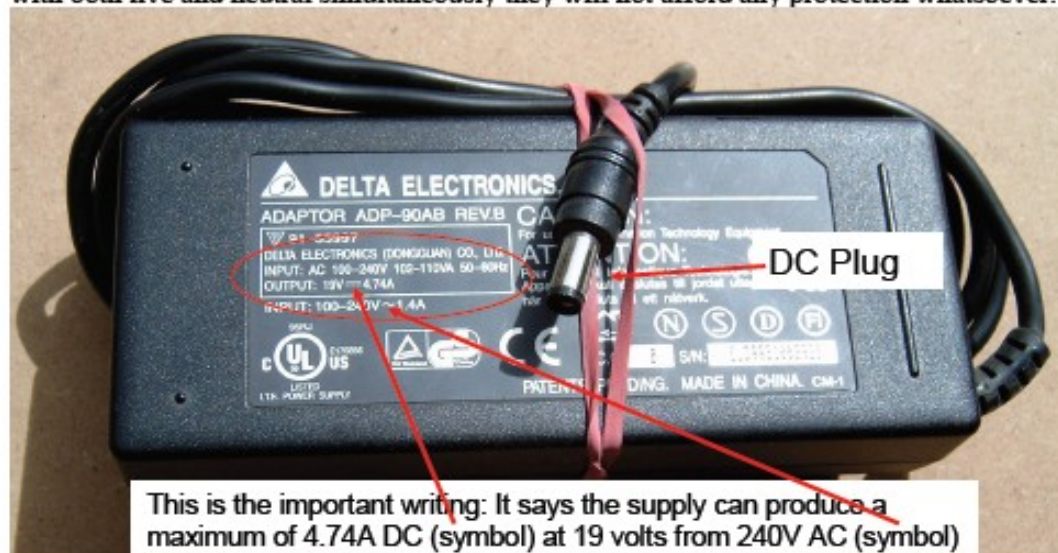

Figure 2 – A DC power brick with 90W output.

On the subject of which ... with the proliferation of electronic gadgets with "power bricks", there is probably a safe supply of low voltage DC a lot closer to hand than might otherwise be thought. Most laptop power bricks produce between 12 and 24 volts at up to

several amps. At the other end of the scale, a mobile phone charger puts out about 5 volts with a maximum current of 0.3A – plenty to drive a small Meccano motor directly. All these power bricks have a label or a moulded-in specification of what the output voltage and current for the device is. The type of plug on the low-voltage end is usually a giveaway too. In the photo of **Figure 2**, the red circle highlights the important information with the symbols for DC (solid & dashed horizontal lines) and AC (a ‘ ~ ’). In a later article I will describe how to make a simple variable voltage supply for driving motors etc. at different speeds.

3. Switches and Diodes (Part A).

Switches come in all shapes and sizes, but basically perform the same function – the routing of electrical power in a certain way. Switches which behave in an electrically identical way frequently have different names. Below, I have grouped these electrically.

Single Pole, Single Throw	SPST, Off-On,
Single Pole, Double Throw	SPDT, Two-way, Changeover, On-On
Double Pole, Single Throw	DPST, Ganged, Isolator
Double Pole, Double Throw	DPDT, Changeover, Reversing, Intermediate
Centre off, or On-Off-On	Any of the above. The switch has a “neutral” position in the centre and connects different pairs of contacts in other positions.
Biased, or Off-(On)	The switch can be moved to a position but will not stay in that position by itself (like a doorbell, for example).
Normally open, N.O. [§] , Push-to-make.	The switch contacts normally do not contact but when pressed will close (the doorbell again)
Normally closed, N.C. [§] , Push- to-break.	The switch contacts are normally in contact and pressing the switch causes them to open (emergency stop buttons on machine tools, for example)
Push-Push, Bi-stable	The switch uses a mechanism similar to that on the top of ball-point pens such that when pressed, will hold the contacts in either the open or closed positions.

A relay is just an electromechanical switch – a solenoid coil is used to provide the force to change the position of the main electrical contacts.

The control of the direction of rotation of a motor is a good example to illustrate the use of different switch types. The direction in which a DC motor rotates depends on the polarity of the voltage applied to it. **Figure 3** shows the electrical circuit symbol for some different switches and how to connect them up. The photo in **Figure 4** shows a small toggle switch actuated by a handrail coupling. The switch shown in **Figure 4** is a DPDT with centre off. The lever is spring loaded so it normally sits in the middle position

[§] N.O. and N.C. are used to show the position of relay contacts when the relay is not energised.

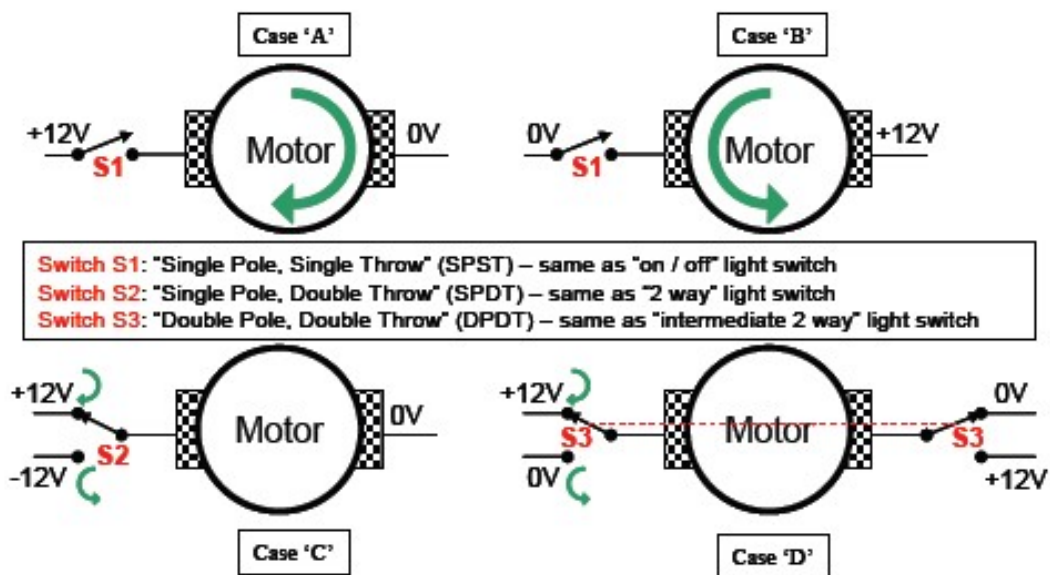

Figure 3 – Different switch configurations for controlling a DC motor.

(where no electrical contact is made, i.e., the motor is off) but can be moved to "forward" or "reverse" positions as desired using the 5 hole strip. In the component catalogues this is called an (On)-Off-(On) switch – the brackets indicating the level is biased or spring loaded so it doesn't stay put in any position except the centre.

Going back to Figure 3:

Case A: Motor rotates clockwise with the voltage polarity shown.

Case B: Reverse the +12V & 0V wires - the motor rotates anticlockwise with switch shut.

Case C: One end of the motor is permanently connected to 0V and the other end can be switched between +12V (clockwise) and -12V (anticlockwise).

Case D. Both ends of the motor can be switched to either +12V or 0V. With the switches "up", the motor rotates clockwise. When "down", the motor rotates anticlockwise. The dotted line connecting the switches signifies they are "ganged" (operate) together.



Figure 4 – DPDT (On)-Off-(On) Toggle switch

Note that in Case C a positive (+12V) and a negative (-12V) supply is needed to change the direction of rotation of the motor whereas in Case D only a single supply polarity is needed.

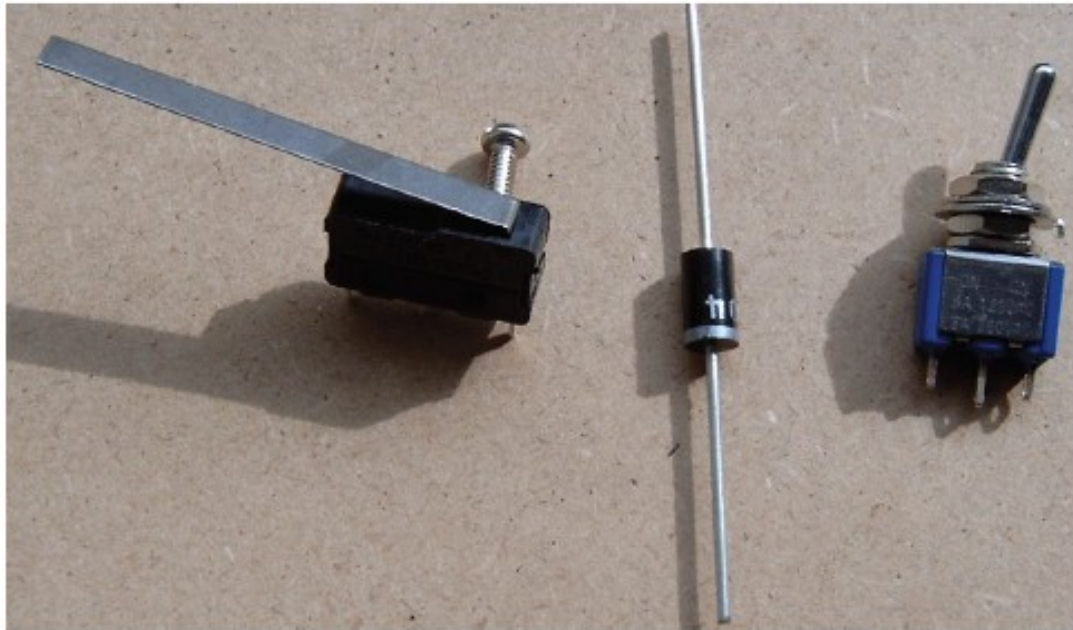

Figure 5 – A microswitch, diode and small toggle switch.

Figure 5 shows a few more components. The switch on the left is called a “microswitch” and is basically a small switch with a very long lever attached. There are usually a couple of holes moulded into the body of the switch for mounting purposes: for the example shown these are only big enough for an M2.5 / 8BA bolt. The middle component is a semiconductor rectifier diode and this behaves like an electronic one-way switch.

In an AC circuit the voltage (or current) changes direction many times per second. The rate at which these changes occur is referred to as the supply frequency, measured in Hertz, and in the UK is 50Hz. In the US the domestic supply frequency is 60Hz. Hertz and cycles per second are exactly the same thing for all practical purposes. If an electric motor or car engine is rotating at 3,000 RPM then the rotation frequency is 50Hz: 3000 revolutions per minute divided by the number of seconds in a minute.

Devices like incandescent light bulbs (i.e., those with glowing filaments) aren't fussy about the type of power they consume – AC or DC (of the same voltage) is equally satisfactory. However, electronic components and DC motors do care. In the case of the DC motor, applying AC to it effectively asks the motor to change direction 100 (or 120 in the USA) times per second. The inertia of the motor's rotor is high and hence the motor will probably buzz loudly and eventually overheat, leading to permanent damage. Electronic components suffer in a different way: because the voltage switches between a positive and negative value at the supply frequency (say 50Hz) then in switching between these two extremes it must pass through zero at twice that frequency, shown in Figure 6. So 100 times per second the power is effectively removed from the electronic circuit. Fortunately it is easy to convert AC to DC using something called a rectifier diode.

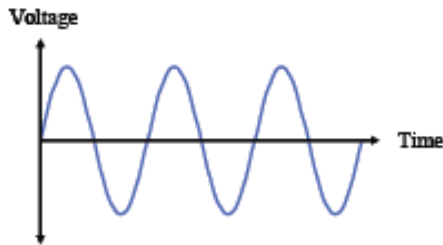

Figure 6 – An AC voltage waveform.

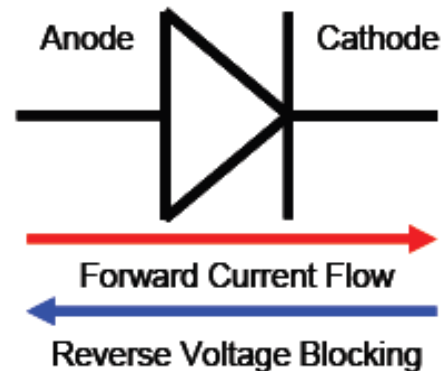

Figure 7 – Electrical symbol and current flow in a diode.

A diode behaves in the same way as a one-way valve or a ratchet mechanism: free movement is allowed in one direction only; in the other it is blocked. The symbol for a diode is shown in Figure 7. Note the diode's "arrow" points in the direction of current flow, which is from the anode to the cathode. In the photo of Figure 5, the silver strip denoted the cathode end of the diode. This convention holds true for diodes – the ring marked on the diode body corresponds to the bar after the arrow in the circuit symbol. If a diode is used with DC then so long as it is facing the right way, current will continue to flow around the circuit. However, if the diode is facing against the direction of current then it will block the flow of current. In an AC circuit, since the current changes direction twice during each cycle, the diode lets through one half-cycle but blocks the other (or vice versa if the diode is put in the circuit "backwards"). Hence, since the current is always of one polarity (positive or negative), AC has been converted to DC, albeit at a lower average voltage than the AC we started with.

Rectifier diodes typically have a "forward" (conduction) voltage drop of between 0.6V (for small diodes) to 1.2V (for very large power diodes). This voltage is largely independent of the current flow once the diode is properly "on". When the diode is "blocking" (i.e., the voltage across it is "backwards"), the reverse current is very small, typically a few nanoamps for small diodes to a few microamps for power diodes. The maximum reverse voltage that can be applied without breakdown occurring (also known as the Peak Inverse Voltage, PIV) will be specified for a particular device. For voltages likely to be found in Meccano models, this generally won't be an issue. However, if this PIV is accidentally exceeded and the current is not limited in some way, reverse breakdown of the semiconductor junction will result in catastrophic and permanent failure of the diode. Fortunately most diodes are fairly rugged and will withstand a fair degree of punishment. If you're unlucky enough to have a diode fail it usually ends up as a short-circuit.

The diode's continuous rating is, as the name suggests, the maximum continuous current the diode can pass without overheating. The heat dissipated is just the product of the voltage drop across the diode multiplied by the current through it. In the case of a rectifier diode carrying a current of 5 amps, with a forward voltage drop of 1.1V, power = $1.1V \times 5.0A = 5.5W$. This is called the conduction loss. The diode junction has a thermal inertia, hence it can withstand short overloads (within reason). The peak current the diode

can stand and the associated forward voltage drop for a 5A device are typically 50A and 2V respectively; an instantaneous power dissipation of 100W. (Never design to the device's transient rating!!) Keeping components cool will be discussed in a later article.

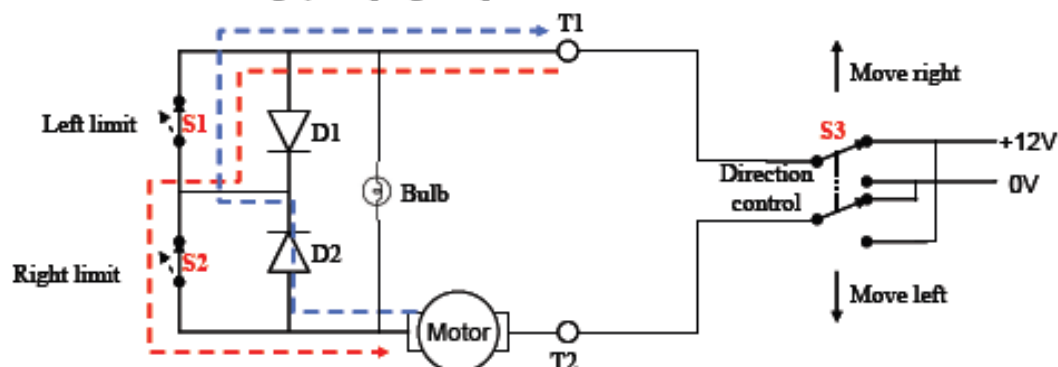

Figure 8 – Use of diodes in limit switch circuit.

Figure 8 shows how a combination of a couple of diodes and switches in a circuit can automatically stop a traveller (Figure 9) at either end of its track. These limit switches are designed to provide hardware protection of the motor, regardless of what the operator wants the motor to do, and will avoid user errors causing damage to the motor and/or model. With reference to the figures, switch S1 is on the left end of the track and switch S2 is on the right end of the track. Switch S3 is used to set the direction of the traveller's motion. When switch S3 is set to move right, terminal T1 is at +12V and T2 is at 0V. If the traveller reaches the right limit switch S2, the switch is opened. Since diode D2 is "against" the flow of current, power can no longer flow to the motor and the motor stops. When S3 is moved to the left, terminal T1 is now at 0V and T2 is at +12V. Under this condition, current flows from T2 via the motor and diode D2 (which is now pointing in the direction of current flow), through switch S1 and back to terminal T1, as shown by the dashed blue line. Thus the traveller can be driven away from the limit condition but no further towards it. As the traveller moves to the left, switch S2 returns to the "closed" position and normal circuit operation is restored. If the traveller reaches the left limit switch, S1, this opens and once again interrupts the power to the motor. When S3 is moved to the right again, this time the current flow is as per the red arrow through diode D1, S2 and the motor. And so the process will repeat. One of the benefits of a system such as this is that it doesn't matter how long the traveller will take to make the journey from one end of the track to the other; the electrical system simply responds when the end of travel in either direction is reached. A typical application for such a circuit would be to control the motor used to move the crab of a large crane along the boom. If the operator inadvertently tries to drive the crab too far in either direction the circuit shown will prevent a collision at either end of the travel. One final remark: if a bulb is placed between the anodes of D1 and D2 as shown it will only light up (i.e., indicate a warning condition) when either limit is reached. When driving off the limit, the forward voltage drop across either diode is insufficient to light the bulb, and the bulb's relatively high resistance is insufficient for motor operation. Hence the bulb does not provide a parallel current path to enable the motor to run against the limit.

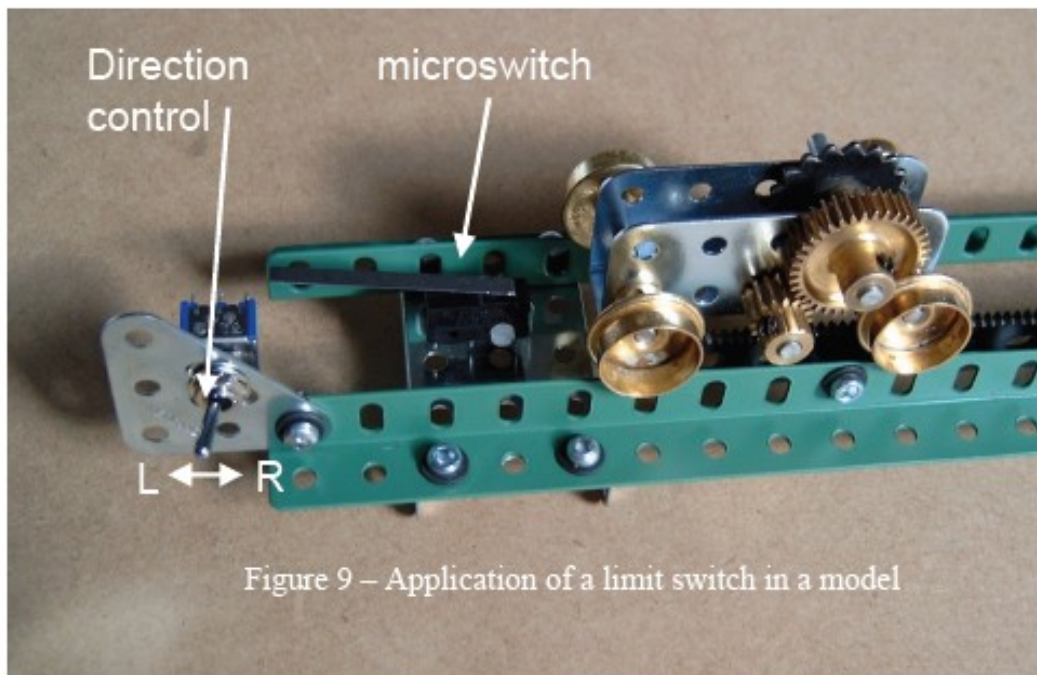

Figure 9 – Application of a limit switch in a model

4. Light Emitting Diodes (LEDs)

An LED is a special type of semiconductor diode designed to emit light from the junction when a current flows through it. Current flow is as per a rectifier diode, i.e., from anode to cathode. The amount of light (the intensity) depends on the current. A wide range of LEDs are available now, from very small devices used for indicators to the “superbright” LEDs used for car lamps. Figure 10 shows just a few. A wide range of colours is also available, from the infra-red to ultra-violet. TV remote controls for example use an infrared LED which is switched on and off very quickly to communicate with the microprocessor in the TV.



Figure 10 – a range of products which include LEDs.

LEDs are semiconductors and hence they are usually very reliable. Many of the LEDs made in the 1970's are still working today (like Landrovers!). Typical lifetime is in excess of 100,000 hours. The forward voltage drop and maximum allowable current depends largely on the type of LED under consideration. The choice of colour also

affects the forward voltage drop to some extent. Table 1 summarises a range of LEDs' parameters.

Colour	Forward voltage drop ("Superbright")
Infrared (long wavelength)	< 1.9V
Red	1.6V → 2.2V
Green	1.9V → 4.0V
Blue	2.5V → 3.7V
Ultraviolet (short wavelength)	3.1V → 4.4V

Table 1 – Voltage drops for different colours of LEDs.

In general, the shorter the wavelength of light, the higher the forward voltage drop. This is due to the physics of the light emission mechanism.

The important parameter which determines the light output of an LED is the current flowing through it. If we want to have equal brightness from different colours of LEDs,

trying to set the voltage at which they each operate is rather difficult. However, if we pass the same current through both LEDs they will (at least to a first approximation) have the same brightness. The technique to achieve this depends on a circuit called a constant current source. More about this later.

The power dissipated by each LED is the product of the voltage drop across it multiplied by the current flowing through it : $P = V \times I$. For the superbright LEDs in car sidelights, the current can be as high as 1 amp, whereas for the small indicator LEDs, currents of a few milliamps (1,000 milliamps = 1 amp) are usual. As stated, LEDs are semiconductors and therefore the temperature at which the device operates is of concern. The typical maximum junction temperature is 130°C. Normally they won't get anywhere near this temperature.

Voltage driving LEDs.

Before we tackle current driving LEDs it is intuitively easier to consider first voltage driving schemes. A simple circuit to drive an LED involves using a DC power supply and a series resistor to limit the current to the desired level. If the LED is to be used from an AC source a rectifier diode should be placed in series too.

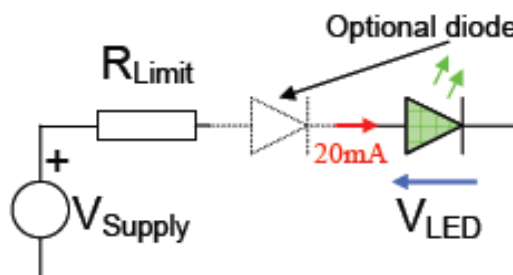

Figure 11

$$R_{Limit} = \frac{V_{Supply} - V_{LED}}{I_{LED}}$$

Equation 1

(The reverse breakdown voltage of the LED is usually quite low; using a rectifier diode with a known voltage rating is much safer.) The circuit diagram in Figure 11 shows how. A drawback with this circuit is that different LED forward voltage drops necessitate the selection of different current limiting resistors. A simple equation to allow you to

calculate the required resistance value is given in Equⁿ 1, and Table 2 shows common values for use with 5V and 12V supplies for different coloured LEDs.

LED & forward voltage drop	Resistor required for I=20mA
Red 1.8V	V _s =5V:160Ω V _s =12V:510Ω
Yellow 2.2V	V _s =5V:140Ω V _s =12V:490Ω
Green 3.1V	V _s =5V:95Ω V _s =12V:445Ω
Blue 3.4V	V _s =5V:80Ω V _s =12V:430Ω

Table 2. Typical resistor values for use with 5V and 12V supplies.

Constant current sources and current driving a string of LEDs.

The first point to make is that in a series connected string of LEDs, all have the same current through them. The output voltage at the terminals of the current source depends on the number of LEDs connected. Figure 12 shows a string of 6 LEDs in series.

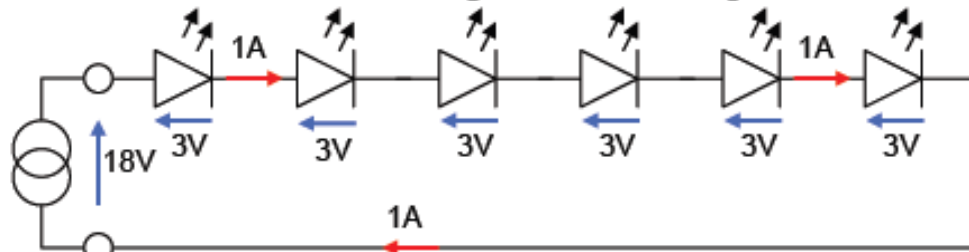

Figure 12 – A string of 6 LEDs in series.

The maximum allowable voltage is called the source’s “compliance”. Most sources of electrical energy (mains, batteries, etc.) are best thought of as a voltage source – the voltage stays the same regardless of the amount of power being drawn. Turning on an extra light in your house doesn’t cause the other lights to become dimmer. The variable quantity is the current which flows according to what the load demands. A current source provides a constant current, regardless of the voltage required, and in this case the variable quantity is the voltage. Power is still volts x amps!

For the string of LEDs shown in Figure 12, because they are connected in series the current flowing through each is exactly the same. However, as more LEDs are added to the string, the voltage between the terminals of the current source increases. If the LEDs are of different colours (and hence forward voltage drops), the current source doesn’t need to be adjusted to ensure that they all have equal brightness, shown in Figure 13.

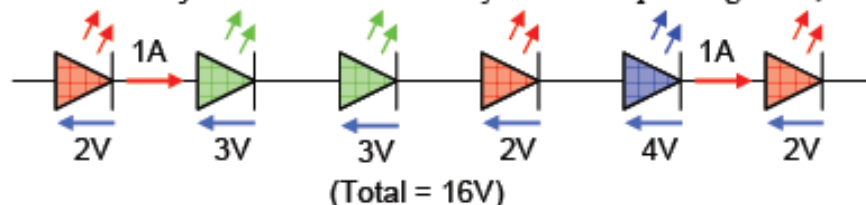

Figure 13 – Different coloured LEDs in series. All have (approximately) equal intensity.

One thing worth noting about voltage-driving LEDs is if the source voltage is too low, the current through the LEDs will be VERY low: in the example of Figure 13 above, if trying to use a 12V car battery to drive the string of LEDs that needs 16V, the current would be so low that it is doubtful any light would be emitted at all. A corollary to this is that it is very bad design practise to rely on a particular battery voltage to deliver the correct current through the LEDs without using a series limiting resistor: the current which flows will be highly temperature dependent, making for unexpected and dramatic changes in illumination between a model displayed in a warm room and a cold tent in Scotland! Current-driving LEDs is slightly more complicated, because of the need for a current source (or sink), but yields a more satisfactory and consistent result.

7 Segment LEDs.

7 segment LED displays are used to show digits 0-9 and sometimes letters of the alphabet. They are formed by packing 7 LEDs in the arrangement shown in Figure 14. Each segment has a letter A-G and is connected as "common anode" (all the anodes are connected together) or "common cathode" (all the cathodes are connected together), shown in Figure 15. Table 3 lists which segments have to be illuminated to show a particular character. Fortunately dedicated integrated circuits are available to convert the digit to be displayed into the appropriate segment pattern. The "Motorvator" control unit uses a couple of 7-segment displays to show programming steps, etc.

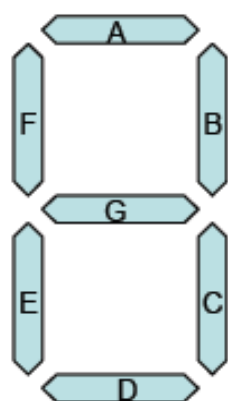

Figure 14. Segment arrangement

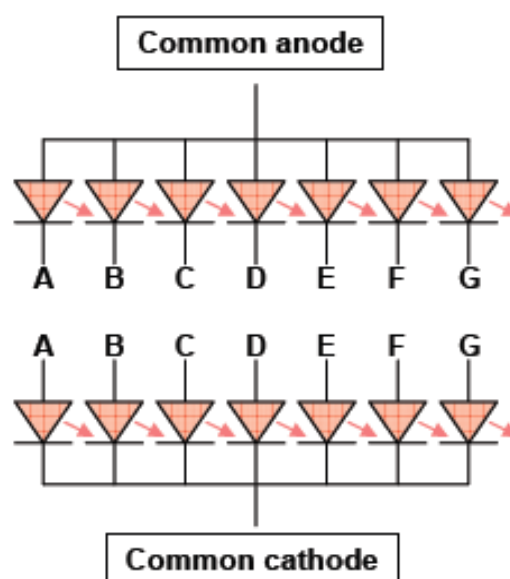

Figure 15. Common anode / common cathode

Digit	A	B	C	D	E	F	G
0	✓	✓	✓	✓	✓	✓	
1		✓	✓				
2	✓	✓		✓	✓		✓
3	✓	✓	✓	✓			✓
4		✓	✓			✓	✓
5	✓		✓	✓		✓	✓
6	✓		✓	✓	✓	✓	✓
7	✓	✓	✓				
8	✓	✓	✓	✓	✓	✓	✓
9	✓	✓	✓			✓	✓

Table 3 – Segment activation according to digit to be displayed.

5. Motors and rechargeable batteries.

This section of the series of articles deals with the use of motors and rechargeable batteries. It is assumed the reader is familiar with the standard torch battery (zinc-carbon) types and these won't be discussed. Similarly, the discussion will be limited to DC motors, i.e. those that can be used with batteries or a transformer with a DC output.

A battery produces a DC voltage and its primary attributes are its output voltage and capacity. The voltage is determined by the number of cells forming the battery and the capacity is a function of the physical size. A battery is usually made from a number of equal cells, and it is the cell which limits what the overall battery is capable of. Taking the familiar example of a car battery, this has a nominal output voltage of 12V and is in fact 6x 2V cells connected in series. The capacity depends on the size, and for most modern cars will be around 75 Ah (Ampere hours, discussed shortly). The car battery is a

rechargeable lead-acid type and it is the battery's chemistry which determines the cell voltage. In fact there are 4 common rechargeable battery types: lead-acid (already mentioned), Nickel-Cadmium (NiCd), Nickel-Metal-Hydride (NiMH) and Lithium-ion (Li-ion). There are also a lot more exotic battery technologies being developed, but these are not likely to be found in Meccano models in the near future! Table 4 below summarises a number of different battery types and their parameters.

Parameter	Nickel-cadmium	Lead-acid	Nickel-metal-hydride	Lithium-ion
Energy density* (Wh/kg)	60	40	90	170
Cycle life to 80% capacity	1500	Up to 1000	500	500
Self-discharge / month	20%	5%	30%	<10%
Nominal cell voltage	1.2	2.0	1.2	3.6
Load current^	20C	>5C	5C	>30C
Peak	1C	>0.2C	0.5C	<10C
Best				

* To put things in perspective, petrol has an energy density of approx 14,000Wh/kg.

^ See 'C' ratings, discussed shortly.

Table 4 – Comparison of different rechargeable battery technologies.

The remainder of this section focuses on the lead-acid battery since this is the cheapest and most readily available part. It is also the technology the original Meccano Accumulator used. A cautionary word is in order at this point: rechargeable batteries are capable of producing an extremely high current if short-circuited; sufficient to set even moderately heavy gauge wire on fire. A fuse somewhere physically close to the battery is a good idea.

The “traditional” lead-acid battery used to have a number of chambers that held the liquid electrolyte (sulphuric acid) and care had to be exercised to ensure this didn't leak. (Minis were notorious for the battery acid corroding the support brackets and dropping the battery out of the bottom of the car when going over bumps.) These were called “vented” batteries, identified by a row of little threaded plugs on the top of the battery for topping-up, and have largely been superseded by “valve regulated” designs. The valve-regulated lead-acid (VRLA) battery immobilises the electrolyte in a gel by adding a gelling agent or by absorbing the electrolyte in a fine glass mat used as a separator between plates in the cell. The absorbed glass mat VRLA designs are often referred to as AGM batteries. VRLA batteries can be used in any orientation (even upside down), unlike their vented counterparts. The valve operating pressure is typically in the range 1 -> 3 p.s.i., so unless your models will be underwater or at very high altitude this is not likely to be an issue. Lead-acid batteries tend to be rather heavy for a given capacity: this is what makes the newer technologies such as NiMH and Li-ion attractive for portable hand tools. However, sometimes the weight can be an advantage – e.g. as the counterweight to balance the boom of a large crane for instance.

Battery ratings

Rechargeable batteries are normally rated in ampere-hours (Ah) or watt-hours (Wh) and come in a variety of sizes, shown in **Figure 16**. This rating depends on some very specific conditions that will be discussed shortly. To convert from Ah or Wh to joules is straightforward:

$$1 \text{ Wh} = 1 \text{ Watt for } 3600 \text{ seconds} = 3600 \text{ Joules of energy.}$$

For the ampere-hour, we also need to know the nominal voltage of the battery. E.g., a car battery rated at 12V / 70Ah has an energy storage capacity of:

$$70\text{AH} @ 12\text{V} = 12\text{V} \times 70\text{A} \times 3600\text{seconds} = 3,024,000\text{J}$$

As an aside, it takes about 400,000 joules of energy to boil a kettle of water, and a car battery cannot boil its own weight of water.



Figure 16 – Sealed lead-acid batteries of different sizes.

There are several factors that determine how much of the battery's total capacity may be usefully used but the most important is the discharge rate. The quantity of energy a battery is able to deliver depends on how quickly the energy is transferred from it. For most VRLAs this is typically over a 20 hour period (enough for 2 full days' use at a show). So if a battery is rated at 100Ah, it is implicit that the battery is able to sustain a 5A output current for 20 hours. If the same battery is fully discharged in 1 hour, the discharge current will be 57A, not 100A. In other words, only 57% of the previous energy is available at the output terminals. Conversely, if the discharge period is longer

then a greater Ah “rating” applies – the 100Ah battery discharged in 50 hours yields a discharge current of 2.2A, i.e., a 10% increase over the nominal rating.

A question that naturally arises is, “When is the battery discharged?” This is determined by the voltage measured at the battery’s terminals during the discharge period. If the discharge period is 1 hour or longer, this is 1.80V per cell. If less than an hour, a value of 1.75V per cell is used. The reason for the difference lies in overexpansion of the cell’s plates, leading to permanent damage if the cell is too heavily discharged. The expansion is reduced if the battery is discharged quickly, hence why the lower voltage is allowed. (Completely discharging a car’s lead-acid battery a few times will effectively make it useless as a battery. Don’t confuse “discharged” with “flat” or “dead”.) In order to overcome the confusion that can surround the performance of the battery under various conditions a convention to use the “C rate” has emerged. This is a term that clearly describes a cell’s (or battery’s) capacity. It is also used to express the charging and discharge rates of the battery (See battery summary, Table 4) In the case of the battery’s capacity, it will be also be followed by a number. So for example a 12V 100Ah battery designed for a 20 hour discharge rate will say 12V, 100Ah C20 on it somewhere. **Figure 16** shows some smaller VRLA batteries suitable for models with a 2 ½“ gear wheel to give an idea of size. Note the batteries shown are 12Ah / 12V, 7Ah / 12V and 4Ah / 6V. The red rectangle denotes the positive terminal.

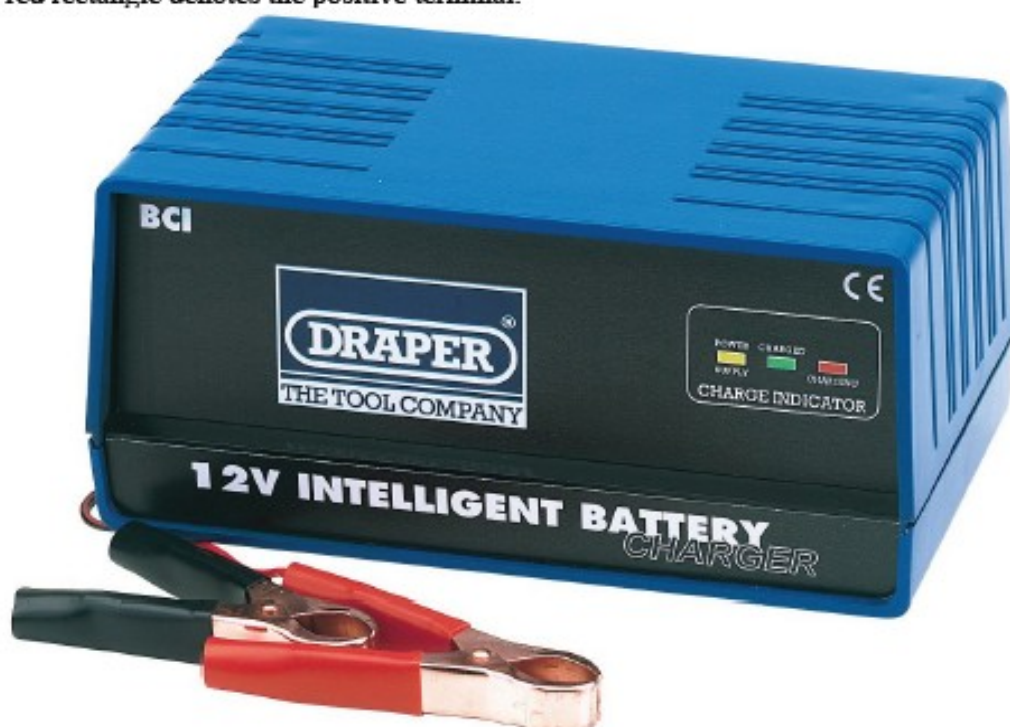

Figure 17 – An “Intelligent” battery charger.

Love your batteries.

Cheap battery chargers can do more harm than good. It is worth spending a few extra £££ to get what’s called a “smart” or “intelligent” (e.g. Figure 17) that adapts the way in

which the battery is charged according to how much charge the battery has in it and the ambient temperature. These chargers contain a microprocessor which carefully monitors the state of the charge of the battery, ambient temperature, etc. and adjusts the charging current and voltage according. Generally a battery can be left charging on one of these chargers indefinitely. "Proper" (as opposed to "fast") charging a lead-acid battery will take between 12 and 36 hours. Different manufacturers make different claims about why their particular charger is "best", but they all basically do the same thing. If you do invest in a smart charger it is worth getting one which will handle different battery voltages as well.

Small DC Motors

Most of the modern motors Meccano provides, either as a separate part (e.g. the M0 and Crane motors) or built into the remote control Tuning kits are DC motors which incorporate a permanent magnet in their design. The Powerdrive also used a permanent magnet DC motor. As a current is passed through a wire a magnetic field is induced around the wire, and the interaction of this magnetic field with the field from the permanent magnet causes the moving part of the motor (the "rotor") to turn. The motor casing usually houses the magnet and this bit is referred to as the "stator". (As an aside, if the rotor of a permanent magnet motor is turned by some means, the motor will actually become a generator, albeit a rather inefficient one). Deciding if the motor to hand is a permanent magnet machine is quite easy – see if bits of Meccano stick to it! One final introductory point – the direction of rotation of a DC motor is determined by the polarity of the input voltage. If the motor rotates the "wrong" way for the model, just reverse the +ve and -ve wires to it. The same thing can be accomplished by using a DPDT switch as described in an earlier article if the model requires bi-directional control of the motor. Usually the motor has a tiny red dot beside the terminal which is nominally positive with respect to the other. Figure 18 shows a range of different permanent magnet DC motors suitable for use with Meccano models, from the small to the very large.

DC motors have two basic electrical specifications which are important to the model builder – the operating voltage and the no-load speed of rotation at that voltage. The M0 motor is rated at 3→6V and has a no-load speed at 6V of about 10,000 RPM; rather fast for most model applications. As the load on the motor is increased so the rotor speed decreases and for small motors the maximum torque they are able to produce is quite low. With suitable gearing this can usually be overcome but this can leave the problem of a rather noisy model, however. The background noise at Skegex in 2011 due to dozens (if not hundreds) of little motors labouring in the bowels of various models was noticeable.

DC motors are remarkably flexible in operation. Continuing with the example of the M0, by using a different voltage a different speed and output torque can be obtained – running at 3V means the speed is approximately half that at 6V, with a corresponding reduction (2X) in the output power. Running motors at a lower voltage than their maximum is usually fairly trouble-free; however, don't run a motor above its maximum voltage because, apart from the risk of overheating, the high RPM can cause internal damage to the motor and bearings.



Figure 18 – A range of smallish motors suited to Meccano models.

Recently a number of really good, inexpensive permanent magnet DC motors have become available which are ideally suited to Meccano models of all sizes. These motors are state of the art in terms of the design: bearings, gearbox (if fitted), magnet strength, etc. and easily out-perform the previous generation in terms of both output torque and power drain. I use a range of different types, each suited to a different application and generally my preference is for a slightly larger motor run at a lower voltage, simply to keep the noise down as much as possible. It also eases the problem of a large reduction ratio, especially where space is limited. Many small motors have an 1/8th inch diameter shaft and with the aid of a short length of 4mm brass tube and some threadlock these can be easily adapted to the standard Meccano size. Various motors are marked as A → G in Figure 18 and their important parameters are summarized in Table 5. The significance of this table is to provide a guide as to how long a particular battery is able to drive a model for, assuming a light to moderate load on the motor (the more power the motor has to deliver, the faster the battery will be discharged). Taking the example of 'D' – using a 12V / 7Ah battery on light load this motor will run a model continuously for 140 hours (almost six days continuous running) without a recharge whereas the Crane motor would have exhausted the battery in a little over a day. Add to that the RS motor is almost silent at 12V and produces masses more torque, and it really is a no-contest. New motors are worth it!

The gear motor 'C' is available on eBay for about £6. A range of speeds from 3RPM to 1000RPM at either 6 or 12V is available (the model tested was 12V / 200RPM) and

features an output shaft of 4mm diameter with a flat machined on it to accept the set / grub screw. Again, performance is excellent but with a slightly higher noise level due to the gearbox.

Letter	Type	Volts	Light Load	Heavy Load	Stall Current	Hrs/Ah Running	Performance
A	Crane	3 → 6	250mA	1A	>2A	4	Poor
B	Powerdrive	1 → 6	100mA	200mA	500mA	10	Good
C	Gear motor	1.5 → 12	50mA	100mA	300mA	20	Excellent
D	RS Components	3 → 24	50mA	300mA	1.5A	20	Excellent
E	M0	1.5 → 6	100mA	500mA	1A	10	Fair
F	Meccanoman	2 → 12	300mA	1A	>3A	3	Average
G	Como Drills	3 → 15	1500mA	3A	>15A	40 mins	Dubious

Table 5 – Comparison of motor performance for motors shown in Figure 18.

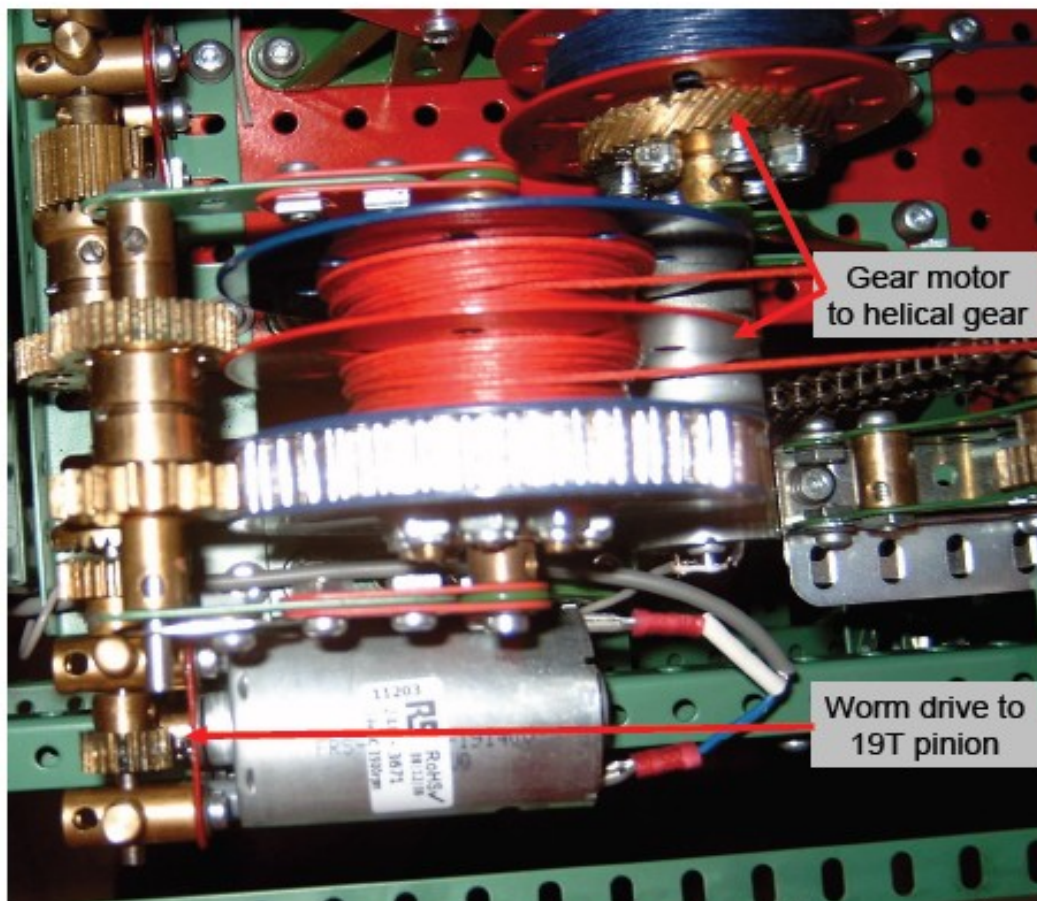

Figure 19 – Motors in a crane winding house.

Figure 19 shows a typical application for a couple of motors – in this case the winding house of a large crane. Type ‘C’ has a 14T helical gear fitted to the output shaft and drives an auxiliary hook winding drum. The type ‘D’ motor has a Worm fitted on the output shaft and drives a 19 tooth pinion which in turn drives the main hoist. By the removal of complex gear trains extremely compact models can be built using these motors.

One final point to close this article – recently non-rechargeable Lithium Thionyl Chloride batteries have become available in standard ‘C’ and ‘D’ cells sizes. **Figure 20** shows a set of 4 batteries in a plastic holder (available from Maplin etc.). These cells have a remarkable capacity and shelf life – those shown in the photo have a capacity of 19Ah (at C100), an output voltage of 12V and a shelf life of at least 25 years. A single cell and a type ‘C’ motor would run a model 8 hours per day, every day, for nearly 7 weeks. These are a cost-effective alternative to the standard Zinc-carbon batteries and represent a true fit-and-forget battery for a regularly displayed model. The only caveat on their use is the need for a periodic shaking of the battery – they seem to fade if left motionless for extended periods of time (months).



Figure 20 – High capacity non-rechargeable batteries.